

# 15/30Jwin – P2

## GAS SENSOR / TRANSMITTER

Safe Area Detector Head / offering local control and display

Specification Sheet C1809Av.2

Doc No. 296 D9C

- Robust and weatherproof
- CANbus, 4~20mA output
- Addressable or stand alone
- Data logging
- Adjustments – non intrusive magnets/manual/hyperterminal
- Back lit alpha numeric full status display
- Optional 3 selectable alarm relays
- Optional sounder/relay
- Optional pumped aspirated sensor



The 15/30J enclosure has been designed to allow quick and easy access to its interior by adjustment of two allen screws, this factor is a major consideration when large system service and calibrations are being carried out.

The detector is robust and weather-proof with improved response times due to the four mounting spacers allowing increased air movement around the detector these spacers also improve the mounting of the unit particularly on circular pillars typically found in car parks. Standard 4~20mA signalling with CANbus address enables the sensors to be networked via the GDS Combi control system or customer preferred monitoring system.

### Power Supply

15 to 30vDC 24v nominal

### Outputs

3 wire – 4~20mA

4 wire – CANbus

### Relays (optional) 1, 2, 3

Selectable: Low, High, Overrange, Fault

Default settings:

1 – Low alarm

2 – High alarm

3 – Fault alarm

Rating 3A @30vDC S.P.C.O

Inhibit option during servicing

### Sounder/Relay (optional)

Single relay – Low / High alarm selectable S.P.C.O

Sounder – not less than 85dB @30cm

### Indicators

Alarm – Red L.E.D

Fault / Inhibit – Amber L.E.D

### Display

2 line alpha numeric back lit status display:

– gas type

– concentration units

– alarm levels

– alarm status (low/high/over range/fault)

– sensor ID

### Logging

Intervals – variable time

Roll over/stop

Storage – 2,880 readings

### Temperature

-15 °C to 55 °C

### Humidity

Electrochemical sensor

5 –95% RH non condensing

## DETECTOR HEAD

Type – P2 Safe area use

### Ingress Protection

IP63 + Universal fitting IP64

### Material

ABS – black

### Sensor Inserts

7 series type  
Electrochemical

### Accessories – Optional

Collector Cone + Universal Fitting  
Universal Fitting (test gas applicator/spray deflector)  
Flow Block  
Duct Mount Kit  
Detector Head Weather Shield

## JUNCTION BOX

Type – 15/30J safe area use only

15J – shallow box (S)

30J – deep box (D)

### Ingress Protection

IP64

### Material

ABS Flame retardant FR40  
Lid Screws M4SS

### Finish

Signal White RAL 9003

### Weight

380gms

### Entries

Rear 5-20mm knock outs  
Sides, Top, Bottom – not specified

### Mounting

Standoffs – M4 or No 8 screws  
Drill at (C) when standoffs removed  
Conduit box – drill at (A) 4.5mm  
Surface mount box – drill at (B) 4.5mm

### EU Design No.

01359723-0001

## TRANSMITTER TECHNICAL DATA

### Documents

Toxic/Oxygen – C1882

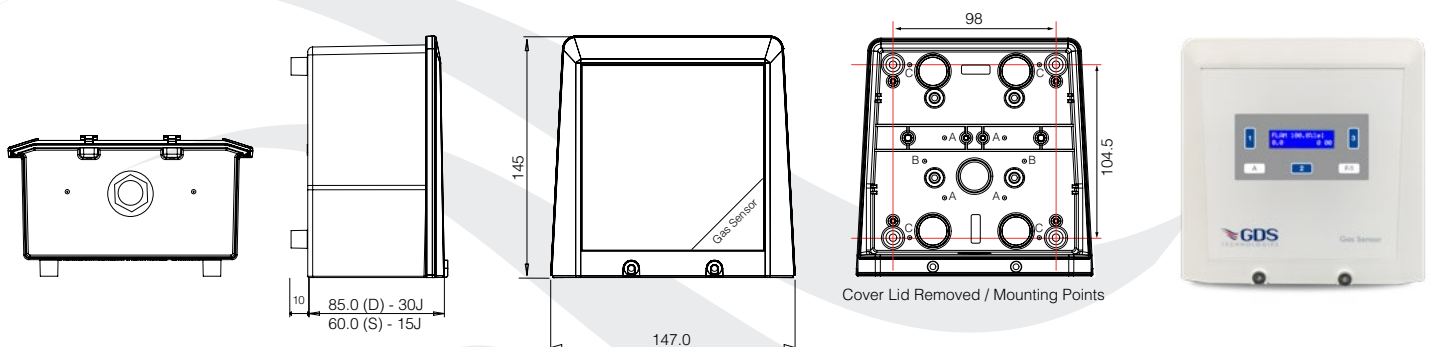

This document is not contractual and the specification/detail may be modified at any time without prior notice.

E: sales@gds-technologies.co.uk T: +44 (0)113 286 0166

GDS TECHNOLOGIES LTD | FUSION POINT | ASH LANE | GARFORTH | LEEDS | LS25 2GA | UK

